

APPLICATION FOR CERTIFICATE OF APPROPRIATENESS (COA)

Building address 601 E. 4th St.
Owner of building 601 E. 4th St LLC Phone
Owner's email & mailing address
Applicant Bruce Campbell Phone:
Applicant's email & mailing address
Street and Number City State Zip Code

APPLICANT MUST ATTEND MEETING FOR CASE TO BE HEARD.
USE THE CHECKLIST ON THE BACK OF THIS APPLICATION TO ENSURE YOUR SUBMISSION IS COMPLETE.

Historic & Architectural Review Board - Application form, photographs, and drawings must be submitted 2 weeks prior to the regular scheduled meeting in order to be placed on the agenda for the next meeting.

South Bethlehem & Mount Airy Historic Conservation Commission - Application form, photographs, and drawings must be submitted 2 weeks prior to the regular scheduled meeting in order to be placed on the agenda for the next meeting.

1. PHOTOGRAPHS - Photographs of your building and neighboring buildings must accompany your application.

2. TYPE OF WORK PROPOSED - Check all that apply. Please bring any samples or manufactures specifications for products you will use in this project.
Trim and decorative woodwork
Siding and Masonry
Roofing, gutter and downspout
Windows, doors, and associated hardware
Storm windows and storm doors
Shutters and associated hardware
Paint (Submit color chips - HARB only)
Skylights
Metal work
Light fixtures
Signs
Demolition
Other

3. DRAWINGS OF PROPOSED WORK - Required drawings must accompany your application. Please submit ONE ORIGINAL AND TEN (10) COPIES OF DRAWINGS, PHOTOGRAPHS, APPLICATION FORM, AND ANY SPECIFICATIONS
Alteration, renovation, restoration (1/4 or 1/8"=1'0" scale drawings required IF walls or openings altered.)
New addition (1/4" or 1/8"=1'0" scale drawings: elevations, floor plans, site plan)
New building or structure (1/4" or 1/8"=1'0" scale drawings: elevations, floor plans, site plan)
Demolition, removal of building features or building (1/4" or 1/8"=1'0" scale drawings: elevation of remaining site and site plan)
A scale drawing, with an elevation view, is required for all sign submittals

4. DESCRIBE PROJECT - Describe any work checked in #2 and #3 above. Attach additional sheets as needed.
Demo rear Apartment, replace with deck
Replacement windows
Shutters
Doors

5. APPLICANT'S SIGNATURE DATE:



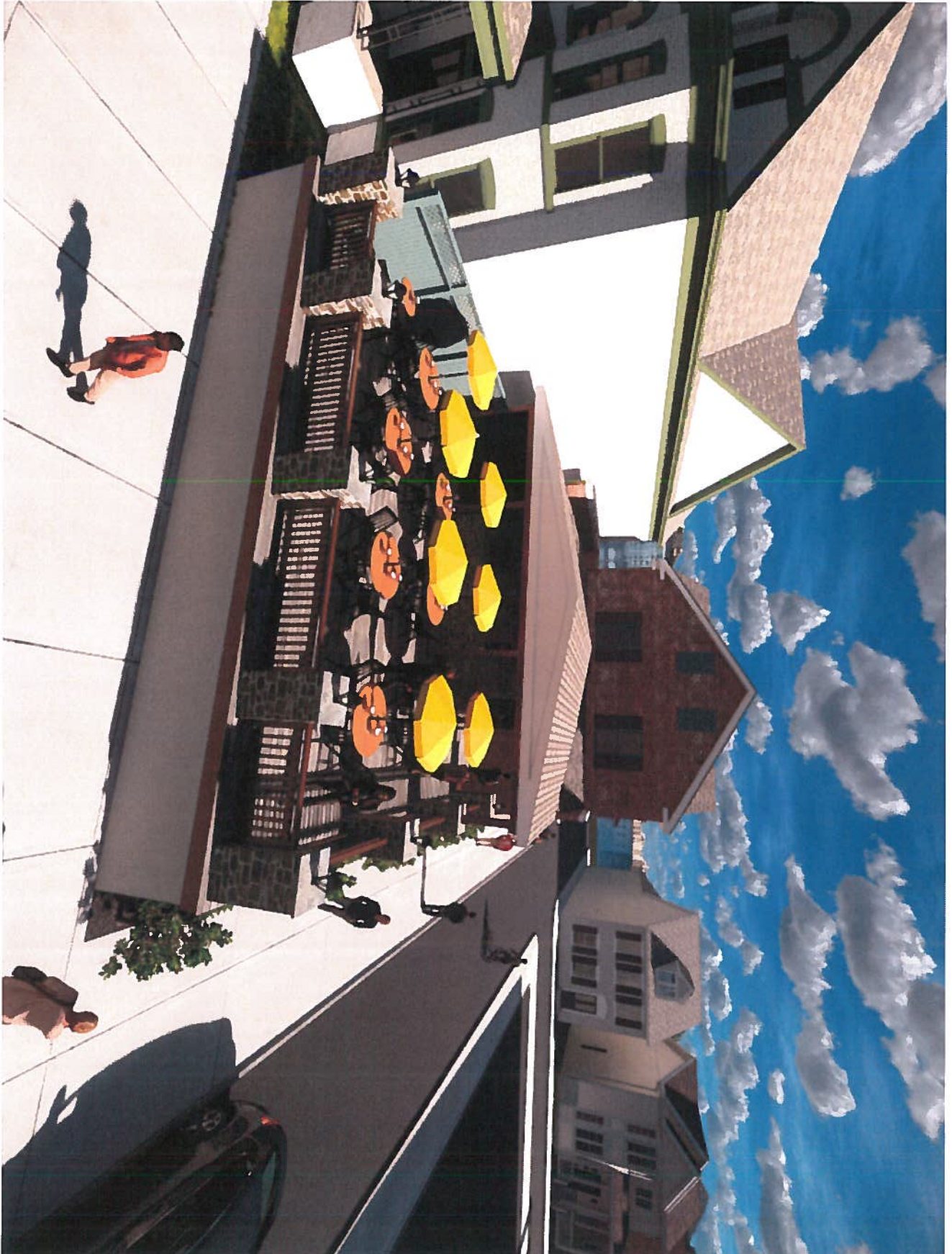





21

NO SMOKING
DOES NOT
OFFER A
NON-
SMOKING
AREA

CLOSED CIRCUIT
TELEVISION
AND
AUDIO MONITORING
ON PREMISES











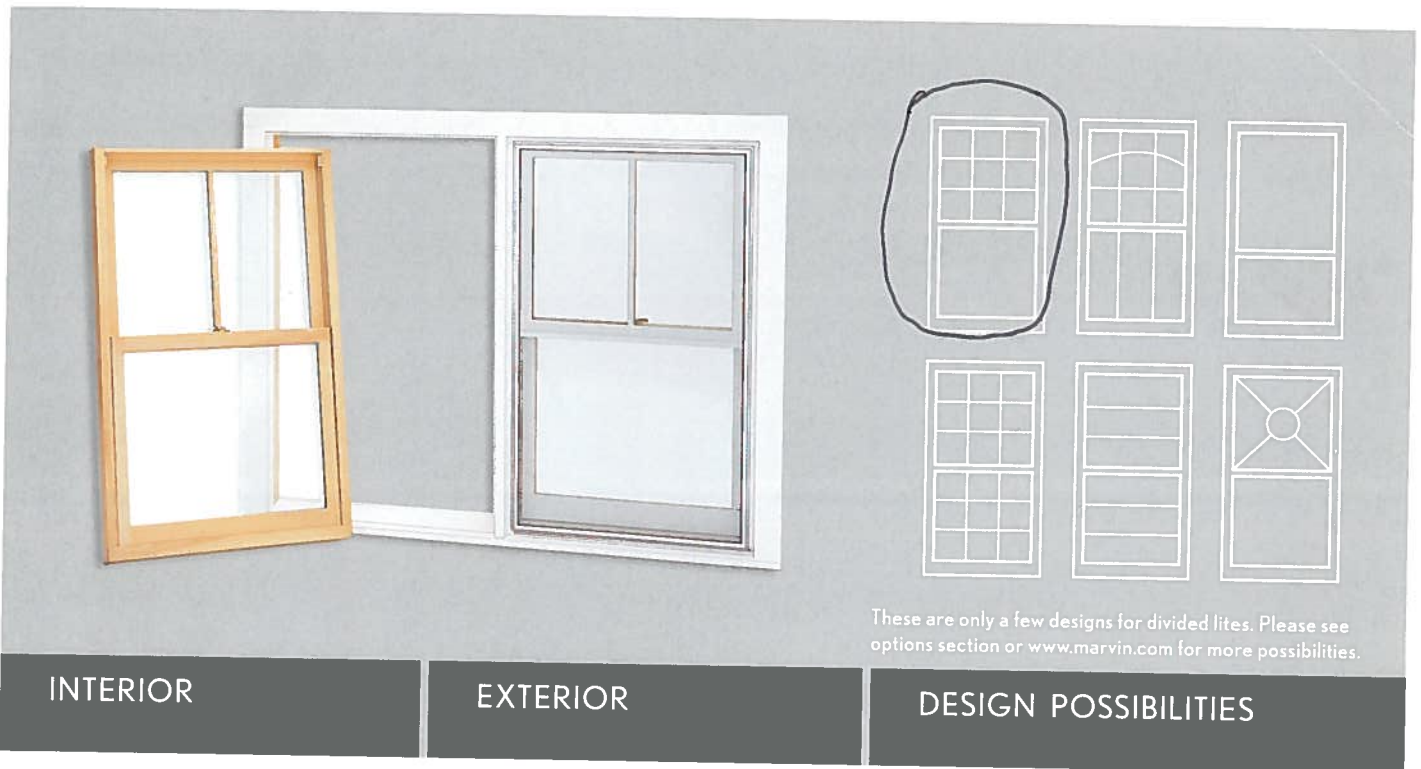

These are only a few designs for divided lites. Please see options section or www.marvin.com for more possibilities.

REVIVE THE BEAUTY WHEN YOU REPLACE THE WINDOW.

With the Ultimate Insert Double Hung replacement window you have a beautiful alternative to vinyl replacement windows. There's no need to take out the current frame, remove trim or replace wallpaper. The frame-in-frame design is crafted specifically to your window opening so it fits perfectly into the existing space. Options like a flat or beveled bottom sill ensure a snug fit. The sash even tilts or comes out for easy cleaning so there's less work and more time to enjoy the scenery. And Marvin's vast array of hardware finishes, wood species and clad colors means you'll get the exact look you want.

STANDARD FEATURES

- One-lite Low E II with argon insulating glass
- Satin Taupe sash lock
- Bare wood interior
- All wood exterior (wood units)
- Extruded aluminum clad exterior (clad units)
- 4 5/8" (116 mm) jambs (wood units)
- 3 1/4" (82.5 mm) jambs (clad units)
- Installation hardware

HARDWARE

SASH LOCK



SASH LIFT



(optional)

DETAILS



TILTING SASH.

The hardware easily operates with one hand so hard to clean areas become accessible with the tilt feature.

See foldout for more options.

Windows

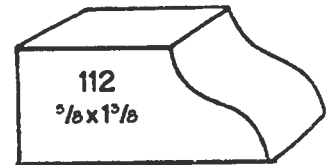
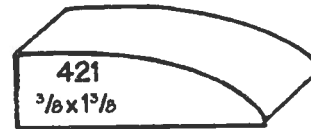
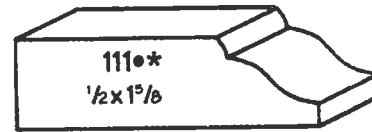
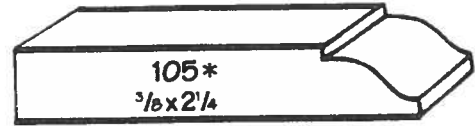
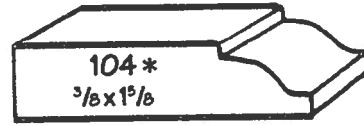
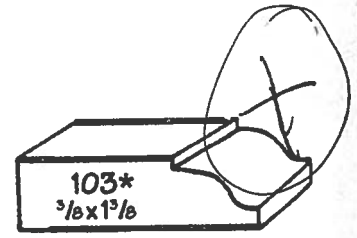
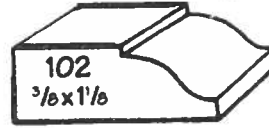
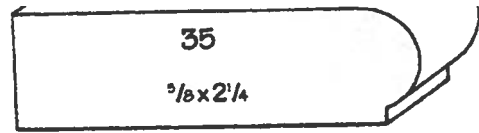

ALSO AVAILABLE IN • MAPLE, CHERRY, MAHOGANY

DYKES

37

CROWNS

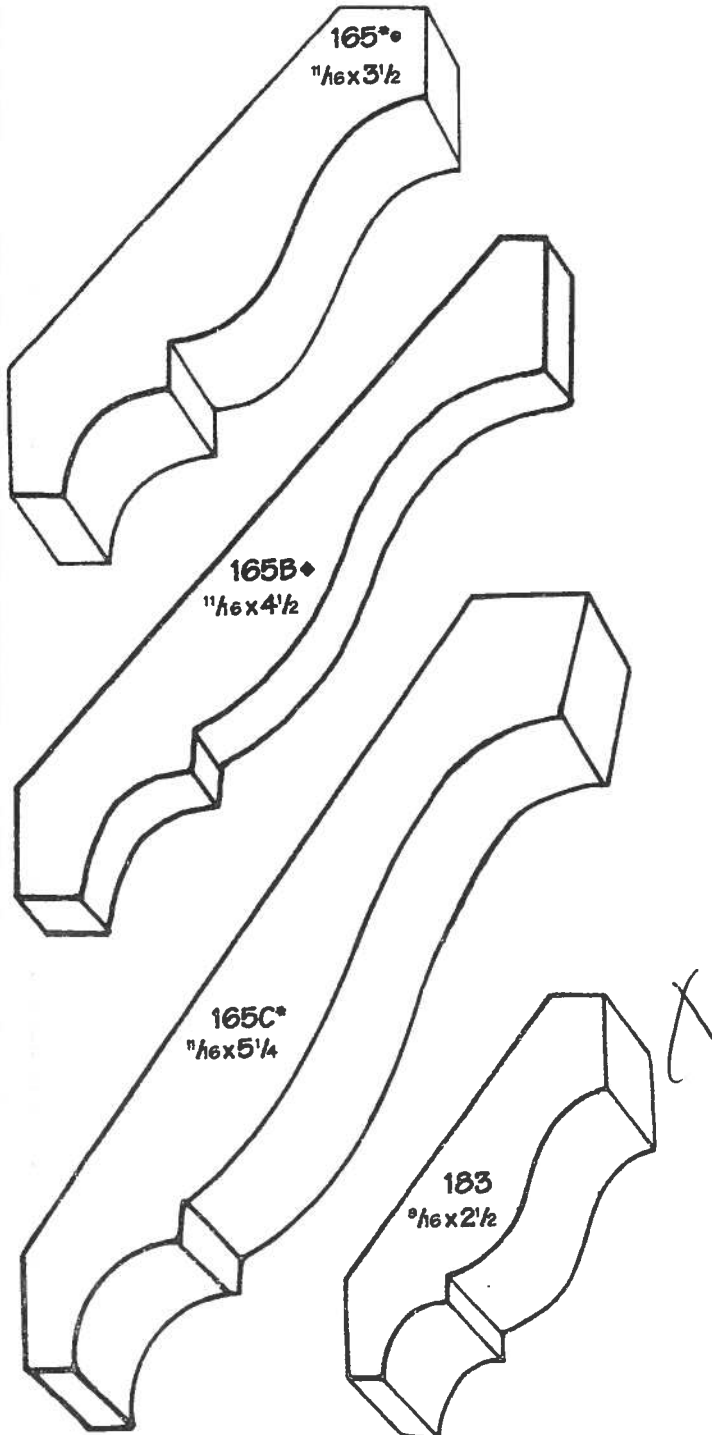

* PRIMED FJ PINE ♦ PRIMED ULTRALIGHT MDF

LINE ITEM QUOTES

The following is a schedule of the windows and doors for this project. For additional unit details, please see Line Item Quotes. Additional charges, tax or Terms and Conditions may apply. Detail pricing is per unit.

Line #1	Mark Unit:	Net Price:	1,414.14
Qty: 1		Ext. Net Price: USD	1,414.14

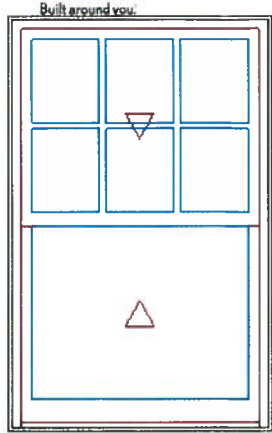

As Viewed From The Exterior
 FS 36 1/2" X 57 1/2"
 IO 36 7/8" X 57 15/64"

Bronze Clad Exterior
 Stained Interior Finish Pine Interior
 Honey Stained Interior Finish 239.12
 Clad Ultimate Insert Double Hung - Next Generation 2.0 931.00
 Frame Size 36 1/2" X 57 1/2"
 Inside Opening 36 7/8" X 57 15/64"
 8° Degree Frame Bevel
 Top Sash
 Bronze Clad Sash Exterior
 Stained Interior Finish Pine Sash Interior
 Honey Stained Interior Finish
 IG - 1 Lite
 Low E2 w/Argon
 Stainless Perimeter Bar
 7/8" SDL - No SBAR..... 176.40
 Rectangular - Special Cut 3W2H
 Bronze Clad Ext - Stained Interior Finish Pine Int
 Honey Stained Interior Finish
 Ogee Interior Glazing Profile
 Bottom Sash
 Bronze Clad Sash Exterior
 Stained Interior Finish Pine Sash Interior
 Honey Stained Interior Finish
 IG - 1 Lite
 Low E2 w/Argon
 Stainless Perimeter Bar
 Ogee Interior Glazing Profile
 Beige Interior Weather Strip Package
 Black Exterior Weather Strip Package
 Oil Rubbed Bronze Sash Lock 67.62
 Oil Rubbed Bronze Top Sash Strike Plate Assembly Color
 Aluminum Screen
 Bronze Surround
 Charcoal Fiberglass Mesh
 ***Screen/Combo Ship Loose
 3 1/4" Jamb
 ***Note: Unit Availability and Price is Subject to Change

Project Subtotal Net Price: USD	1,414.14
6.000% Sales Tax: USD	84.85
Project Total Net Price: USD	1,498.99